

ciena.

Session Begins Soon...





OTN Primer

- Steven Surek
- Consulting Engineer, Ciena Corporation

- December 3, 2008

Outline

- OTN Objectives and Requirements
- OTN Layered Model
- OTN Multiplexing Structure
- OTN Frame Structures
- OTN Overhead Descriptions
- OTN New Standardization Efforts
- OTN Standards and References

The Original DWDM Problem

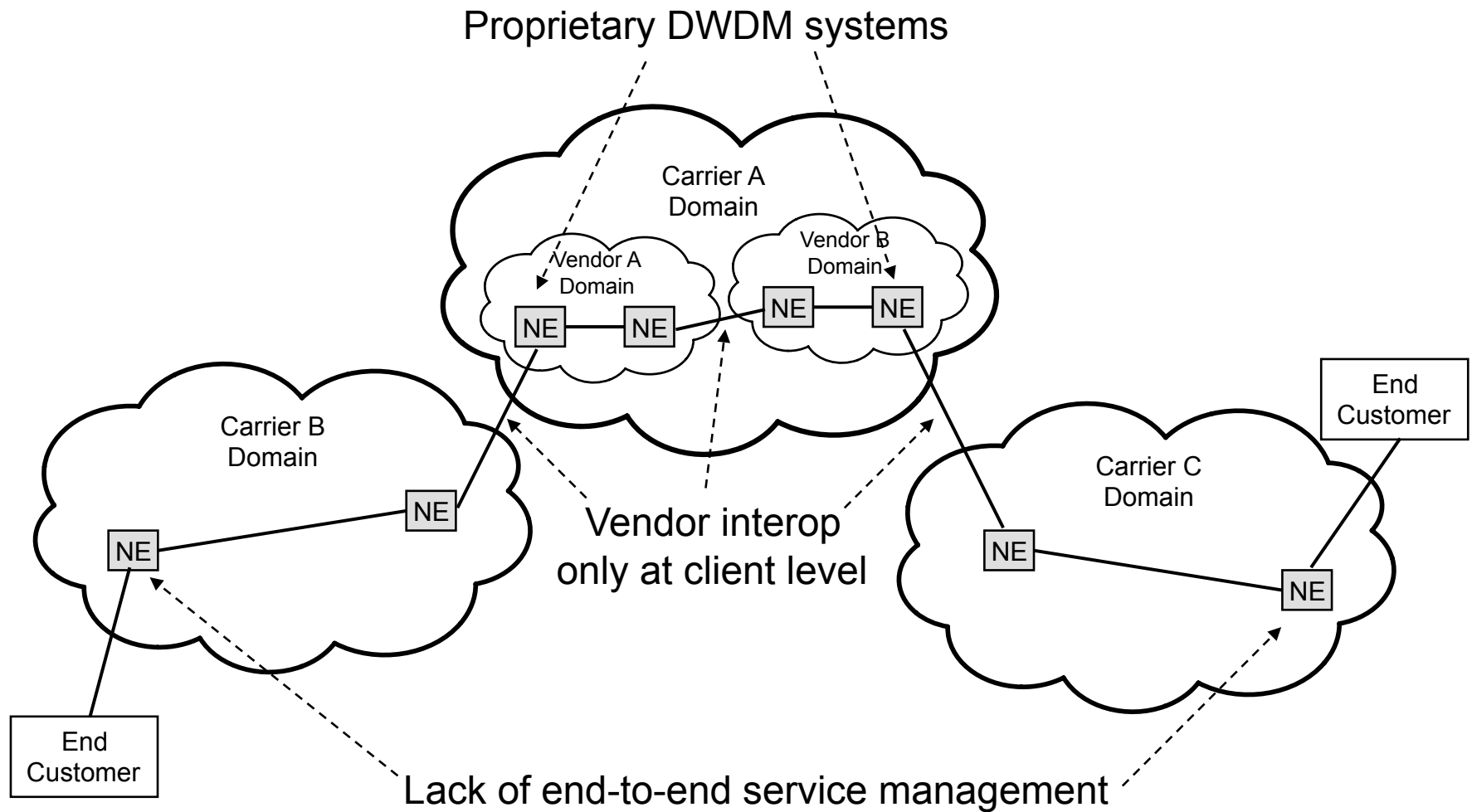

The OTN Solution

Allow DWDM systems with non-standard
Intra-domain Interfaces (IaDI)

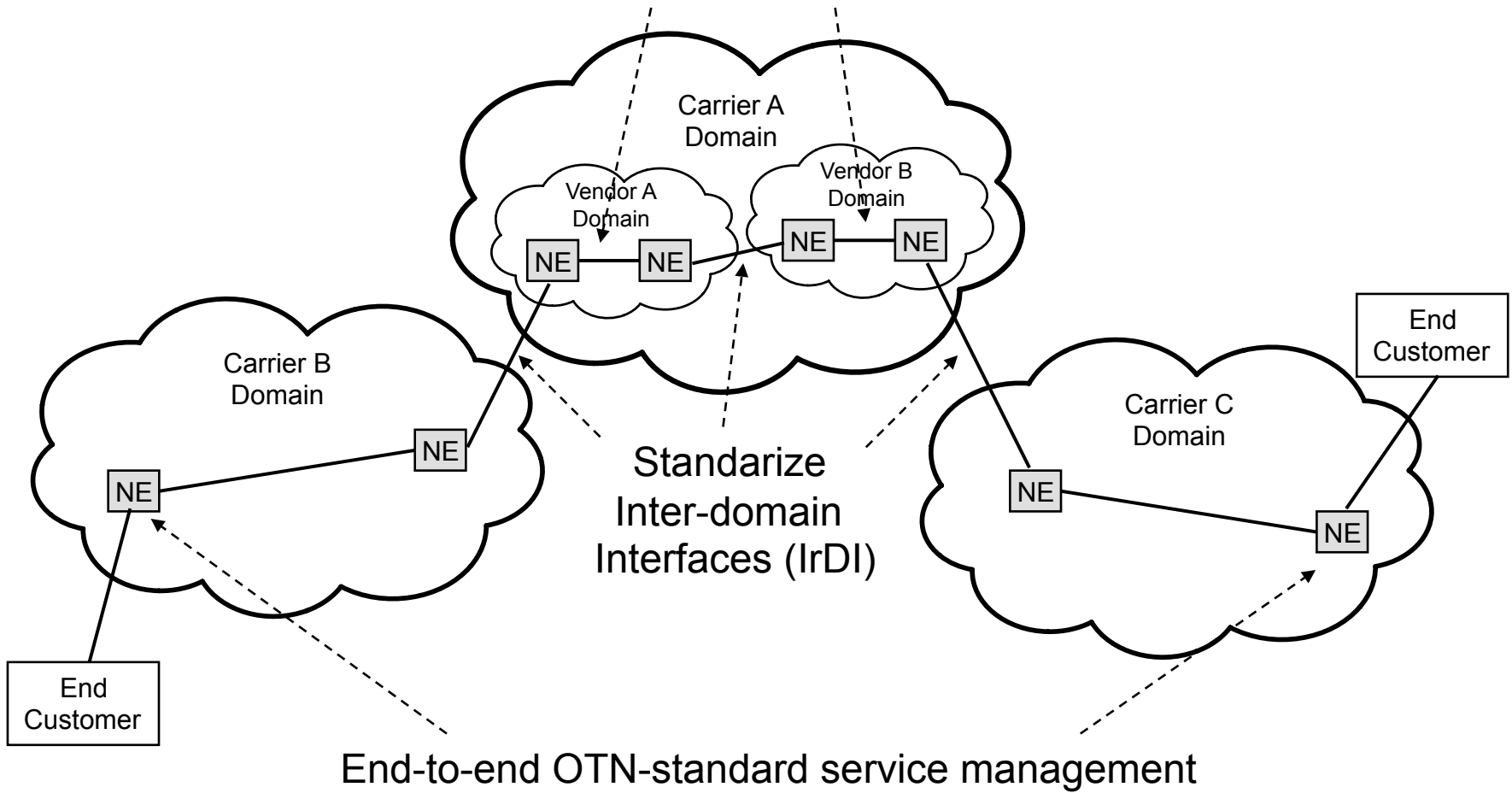

OTN Objectives and Requirements

Standardize Inter-domain Interfaces

- Single and multiple wavelength
- With or Without COMMS capability (Optical Supervisory Channel)
- Standard rates and formats (2.5G, 10G, 40G)

Address Lack of Management Capability of Pure Optical Networks

- Digital wrapper supporting payload transport and management functions
- Provide signal alignment functions, signal quality monitoring, connection and connectivity monitoring, maintenance signal generation and detection, management communications channels, etc.
- Support multiplexing/demultiplexing of services for efficient bandwidth utilization for various line rates

Standardize Forward Error Correction Functions

OTN Layers – End-to-End

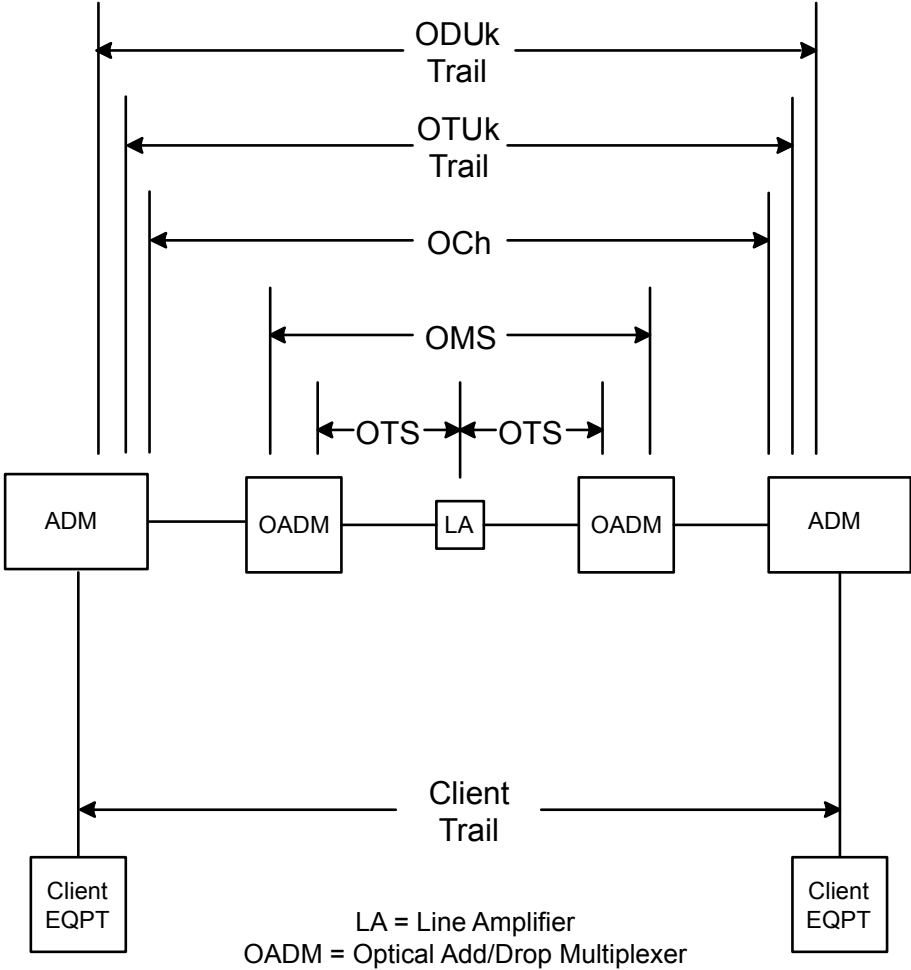

OTN Layer Descriptions – Optical Layers

Optical Transmission Section (OTS)

- Physical optical signal consisting of multiplexed payload wavelengths plus an optical supervisory channel wavelength
- Provides optical amplification, dispersion compensation, and management overhead for the physical optical transmission section

Optical Multiplex Section (OMS)

- Optical signal consisting of multiplexed payload wavelengths (each wavelength representing an individual optical channel)
- Provides optical amplification, dispersion compensation, and management overhead for the physical optical multiplex section
- Provides multiplexing/demultiplexing of optical channels and management overhead for the optical multiplex section

Optical Channel (OCh)

- Represents a single traffic signal (single wavelength), contains optical and electrical functions some of which reside in the OTU frame
- Provides traffic signal generation and recovery (framing, scrambling, FEC, etc.) and management overhead for the optical channel

OTN Layer Descriptions – Digital Layers

Optical Channel Transport Unit (OTU)

- Provides the electrical functions to support the management of an optical channel section, i.e., section monitor (section trail trace identifier, section error detection code (BIP-8), defect indication functions, general communications channel)
- Provides for transport of the optical channel data unit

Optical Channel Data Unit (ODU)

- Provides the electrical functions to support the management of an optical channel data path, i.e., path monitor (path trail trace identifier, path error detection code (BIP-8), defect indication functions, general communications channel, automatic protection switching channel)
- Provides the electrical functions to support the management of tandem optical channel data paths, i.e., tandem connection monitors (tandem connection trail trace identifier, tandem connection path error detection code (BIP-8), defect indication functions, automatic protection switching channel)
- Provides for transport of the optical channel payload

Optical Channel Payload Unit (OPU)

- Supports the mapping of a variety of client signal types (GFP, constant bit-rate (SDH), etc.)
- Provides payload type defect detection

OTN Rates

Level	OTU Rate (± 20 ppm)	ODU Rate (± 20 ppm)	OPU rate (± 20 ppm)
k=1	255/238 x 2.48832Gbps = ~2.666057Gbps	239/238 x 2.48832Gbps = ~2.498775Gbps	2.48832Gbps
k=2	255/237 x 9.95328Gbps = ~10.709225Gbps	239/237 x 9.95328Gbps = ~10.037274Gbps	238/237 x 9.95328Gbps = ~9.995277Gbps
k=3	255/236 x 39.81312Gbps = ~43.018414Gbps	239/236 x 39.81312Gbps = ~40.319219Gbps	238/236 x 39.81312Gbps = ~40.150519Gbps

Note 1: OTN networks operate asynchronously and do not require network synchronization

Note 2: Non-standard rates exist at k=2,3 levels as a result of transparent 10GbELAN mappings

OTN Information Containmentment Structure

OTM - Optical Transport Module
 COMMs - Communications
 OTS - Optical Transport Section
 OH - Overhead
 OMU - Optical Multiplex Unit
 OMS - Optical Multiplex Section
 OCG – Optical Channel Group
 OCCo – Optical Channel Carrier overhead
 OCCp – Optical Channel Carrier payload
 OCh – Optical Channel
 OTU – Optical channel Transport Unit
 FEC – Forward Error Correction
 ODU – Optical channel Data Unit
 TC MOH – Tandem Connection Monitoring Overhead
 TC – Tandem Connection
 L1, Lm – Level 1, Level m
 PMOH – Path Monitoring Overhead
 OPU – Optical channel Payload Unit

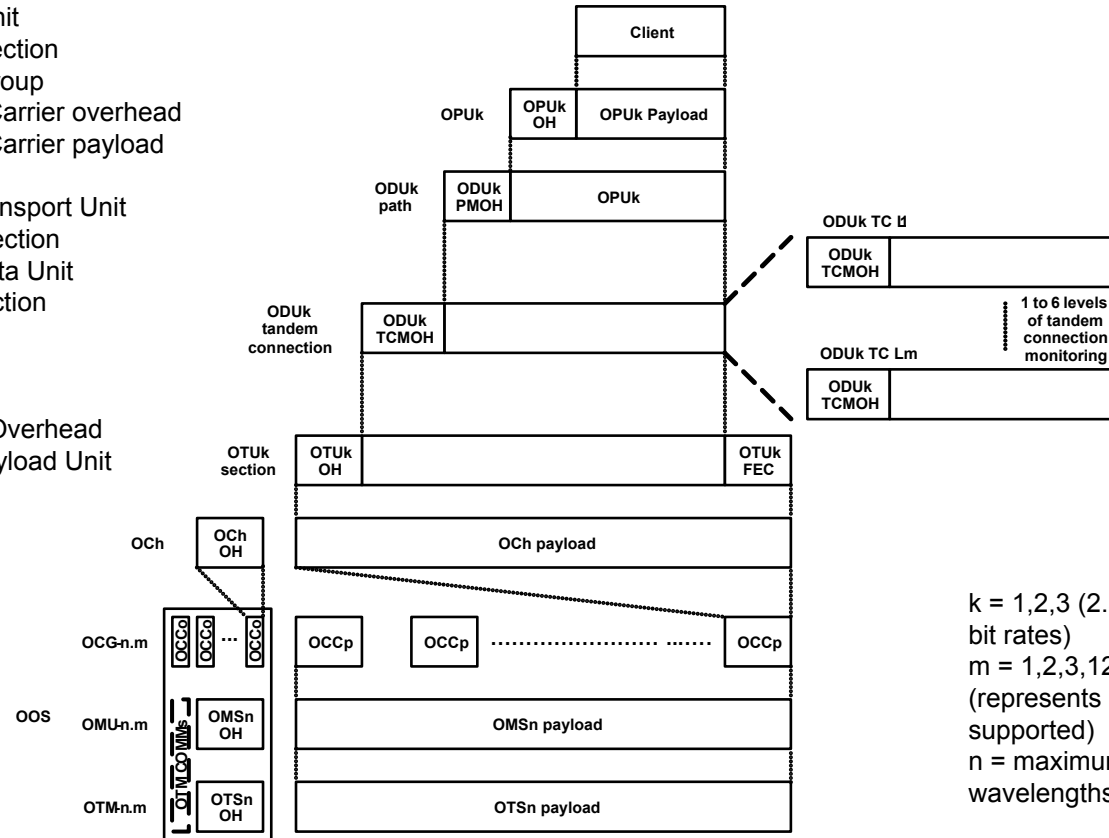

k = 1,2,3 (2.5G, 10G, 40G bit rates)
 m = 1,2,3,12,123,23
 (represents set of bit rates supported)
 n = maximum number of wavelengths supported

OTN Multiplexing and Mapping Structure

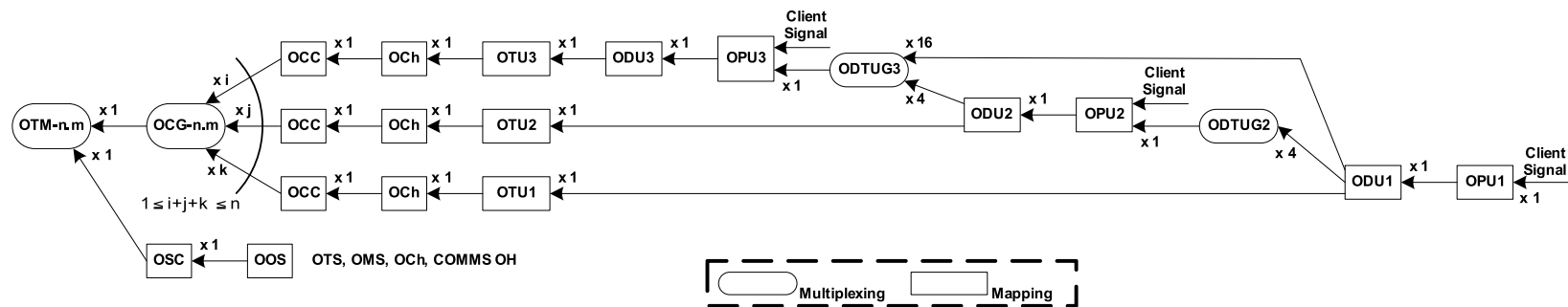

- Client signals mapped directly to optical channel payload unit frame (OPU_k)
- OPU_k mapped into corresponding optical channel data unit frame (ODU_k)
- ODU_k frames mapped to corresponding optical channel transport unit frame (OTU_k) or multiplexed to higher order ODU_k
- OTU_k frames mapped to optical channels (OCh)
- Optical channels mapped to optical channel carrier (OCC)
- Optical channel carriers optically multiplexed into carrier group (OCG)
- OCG combined with optical supervisory channel (OSC) to create the optical transport module (OTM)

OTN Overhead Signals (OOS): Bit Signaling

Each Layer Signal consists of two parts:

- **Payload Signal (-P):** Physical signal carrying service payload
- **Overhead Signal (-O):** Logical signal mainly for fault management purpose
 - **OTS OH:** TTI, PMI, BDI-P, and BDI-O
 - **OMS OH:** PMI, FDI-P, FDI-O, BDI-P, and BDI-O
 - **OCh OH:** FDI-P, FDI-O, and OCI

Signaling transported between nodes over the OSC signal (not standardized)

Signaling function termination/generation

- **OTS OHs** are always terminated/sourced at every node
- **OMS OHs** are always terminated/sourced at every OADM, but pass thru LA nodes
- **OCh OHs** are terminated/sourced at node where channels are dropped/added
- **Express OCh OHs** are forwarded thru the node

OTN Frame Structure

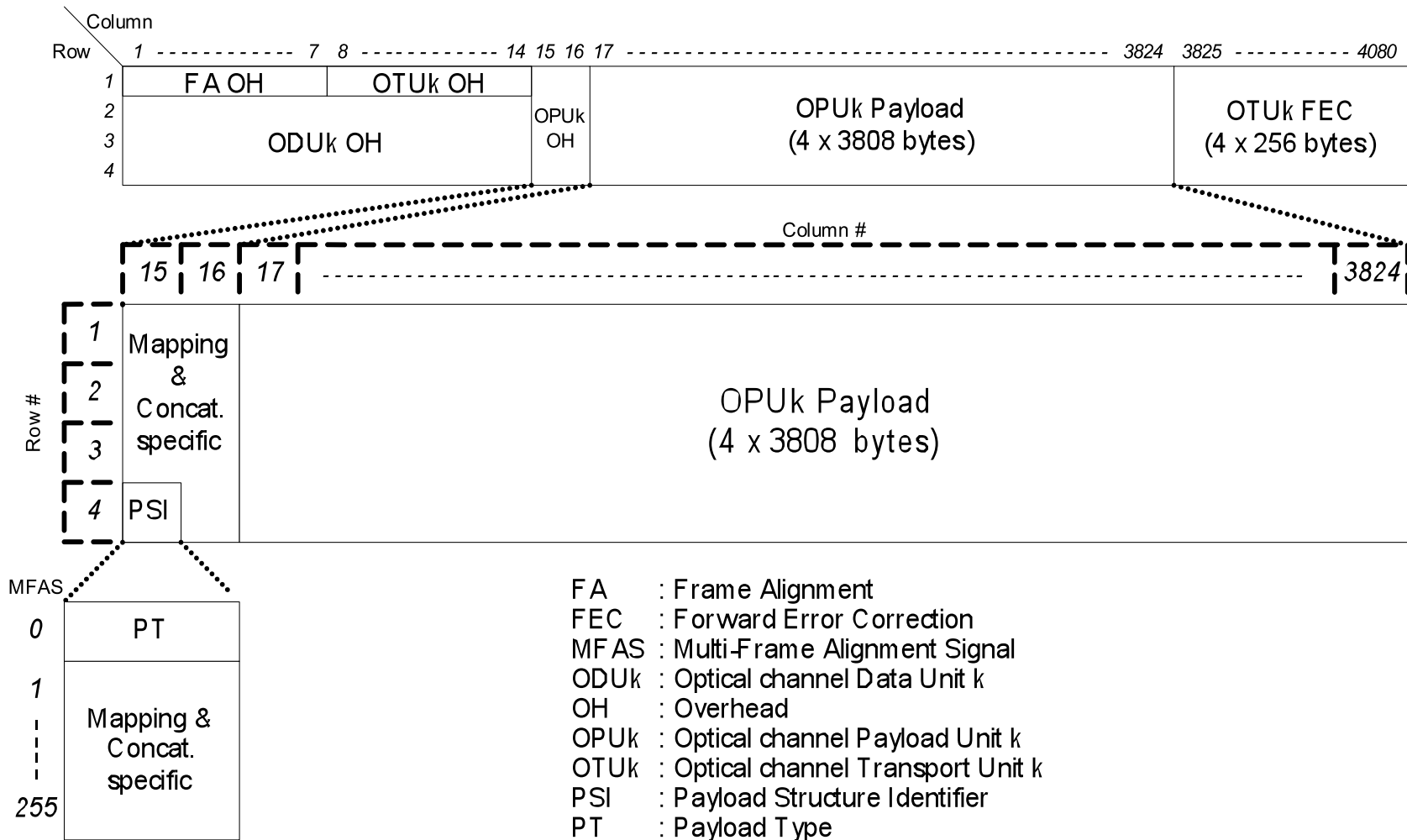

OTUK and ODUK Overhead

		Column #															
		1	2	3	4	5	6	7	8	9	10	11	12	13	14	15	16
Row #	1	Frame Alignment						MFAS	SM			GCC0		RES		OPUk Overhead	
	2	RES		TCM ACT	TCM6			TCM5			TCM4		FTFL				
	3	TCM3		TCM2			TCM1			PM		EXP					
	4	GCC1	GCC2	APS/PCC				RES									

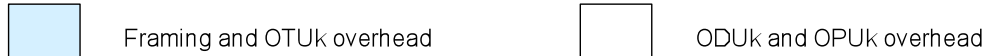

- ACT – Activation/deactivation control channel
- APS – Automatic Protection Switching channel
- BDI – Backward Defect Indication
- BEI – Backward Error Indication
- BIAE – Backward Incoming Alignment Error
- BIP-8 – Bit Interleaved Parity – level 8
- DAPI – Destination Access Point Identifier
- EXP – Experimental
- FTFL – Fault Type and Fault Location channel
- GCC – General Communications Channel
- IAE – Incoming Alignment Error
- MFAS – Multi-frame Alignment Signal
- PCC – Protection Communication Channel
- PM – Path Monitor
- RES – Reserved
- SAPI – Source Access Point Identifier
- SM – Section Monitor
- STAT – Status
- TCM – Tandem Connection Monitor
- TTI – Trail Trace Identifier

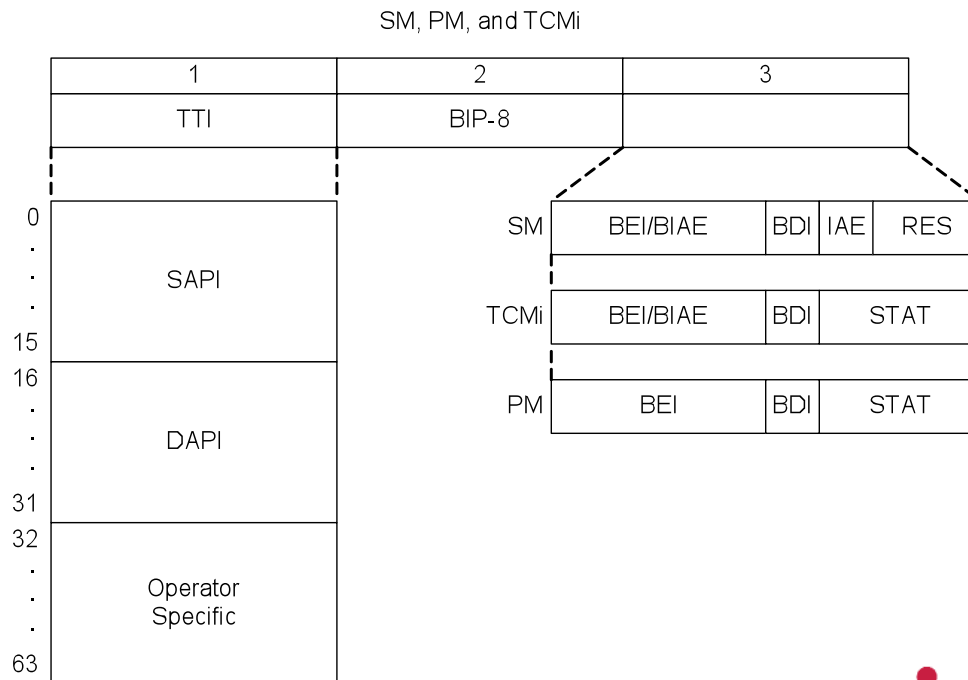

Overhead Descriptions – Alignment

Frame Alignment Signal (FAS)

- Provided in the OTU frame to allow determination of the beginning of the OTU frame
- Detection of framing failure results in Loss of Frame (LOF) indication

Multiframe Alignment Signal (MFAS)

- Provided in the OTU frames to align overhead functions that require multiple frame operation (e.g., Trail Trace Identifier (TTI) functions at OTU/ODU layers; fault type and fault locate, tandem connection activation, mapping functions, and automatic protection switch functions at ODU layer)
- Detection of multi-framing failure results in Loss of Multi-frame (LOM) indication

Incoming Alignment Error (IAE)

- Provided in the OTU and ODU frames to detect frame alignment errors detected by upstream equipment (occurs for through-timed equipment when incoming clock signal is lost)
- Detection of alignment error results in suppression of near-end and far-end performance monitoring data for current and previous seconds

Backward Incoming Alignment Error (BIAE)

- Provided in the OTU and ODU frames to detect frame alignment errors detected by downstream equipment (due to a detection of an IAE at a downstream node)
- Detection of alignment error results in suppression of far-end performance monitoring data for current and previous seconds

IAE and BIAE Processing

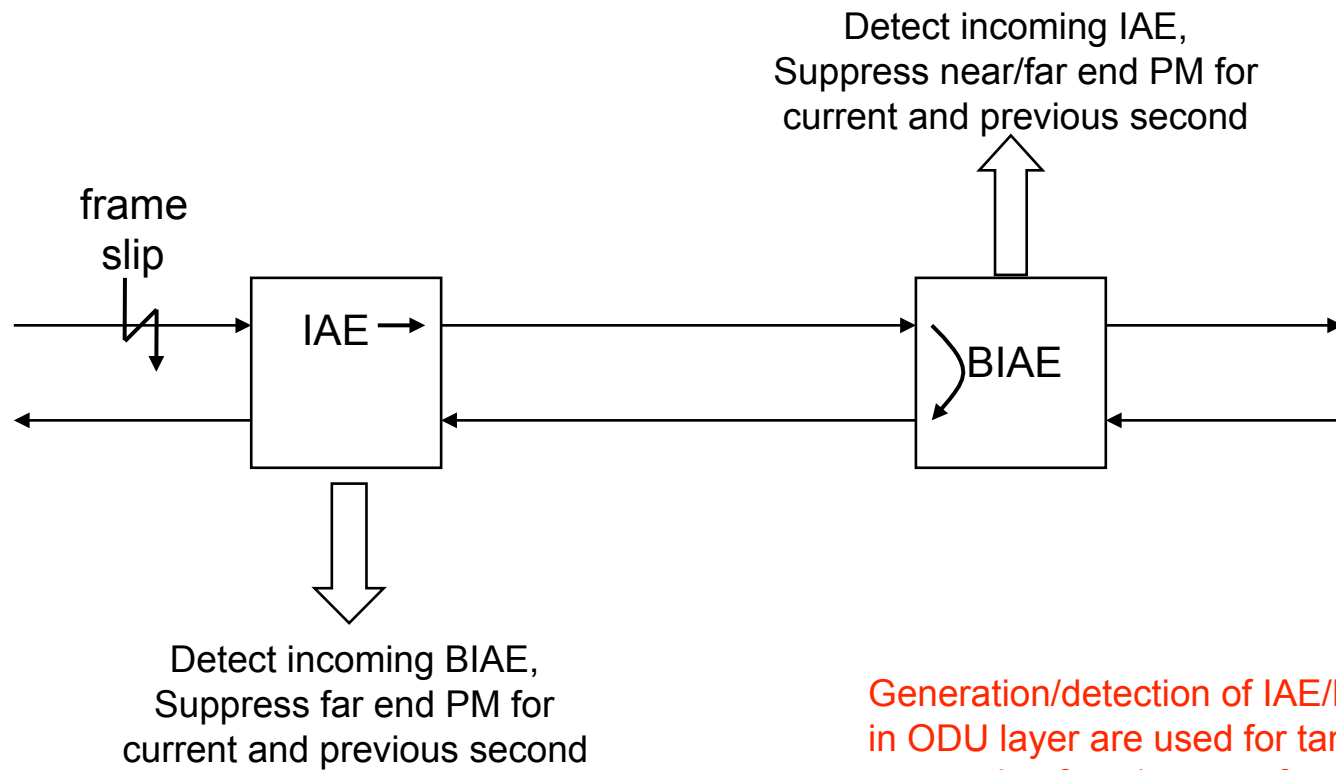

Generation/detection of IAE/BIAE in ODU layer are used for tandem connection functions not for end-to-end path monitoring

Overhead Descriptions –Signal Quality

FEC (Forward Error Correction)

- Provided in the OTU frame to allow detection and correction of line bit errors

BIP-8 (Bit Interleaved Parity-8)

- Provided in the OTU/ODU frame to allow detection of near-end bit errors and support performance monitoring and protection switching functions (Signal Degrade, Note: signal fail due to BER detection not provided)
- Detection of bit error counts are reported to the far end via the backward error indication field (BEI) on a frame-by-frame basis
- Detection of bit errors within a frame generates an errored block (errored block counts are the basis for near-end PM parameter value determination)
- Detection of N successive degraded seconds (based on percentage of errored blocks) results in a Degraded (DEG) indication

BEI (Backward Error Indication)

- Provided in the OTU/ODU frame to allow detection of far-end bit errors and support performance monitoring (single-ended maintenance)
- Detection of bit errors within a frame generates an errored block (errored block counts are the basis for far-end PM parameter value determination) which are reported back to the near-end via BEI bits

BIP-8 and BEI Computations

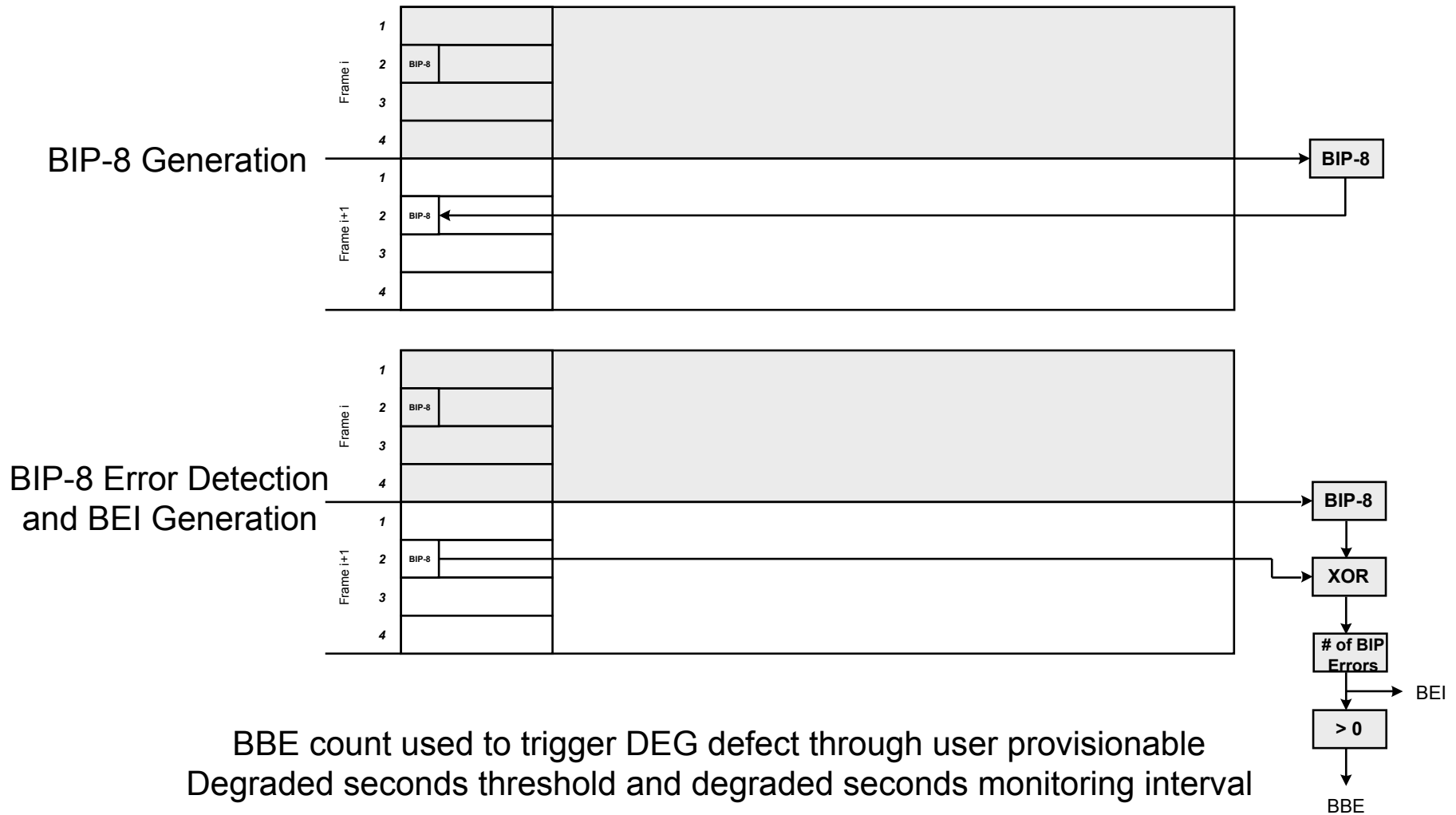

Overhead Descriptions – Connectivity and Continuity

TTI (Trail Trace Identifier)

- Provided in the OTS overhead or OTU/ODU frame to allow detection of connectivity errors
- Supports provisioning of transmitted and expected values and allows retrieval of accepted value
- Provides disabled, source access point identifier (SAPI), destination access point identifier (DAPI), and SAPI+DAPI modes; provides mode for disabling automatic actions due to trace identifier mismatch
- Detection of trace identifier mismatch results in Trail trace Identifier Mismatch (TIM) indication

OCI (Open Connection indication)

- Provided in the OCh overhead or ODU frame to allow detection of continuity errors by indicating that a loss of signal is due to an output connection point is not connected to an input connection point
- At the OCh layer OCI indicates a wavelength not cross-connected
- At ODU layers indicated through '0110' pattern in STAT fields

Trail Trace Identifier Format

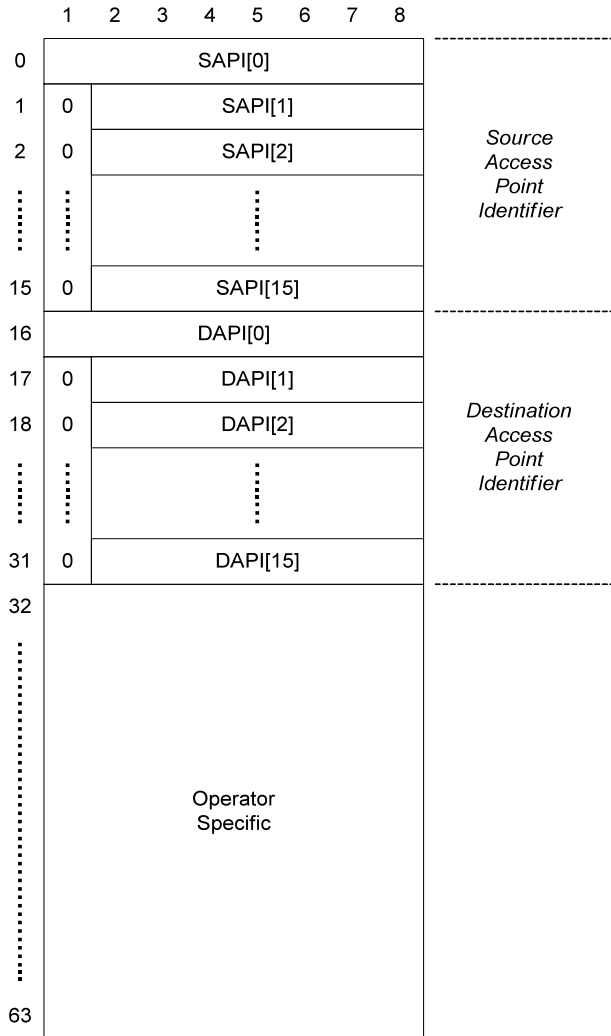

IS character #			NS character #														
1	2	3	4	5	6	7	8	9	10	11	12	13	14	15			
CC			ICC	UAPC													
CC			ICC			UAPC											
CC			ICC				UAPC										
CC			ICC						UAPC								
CC			ICC									UAPC					

CC = ISO 3166 Country Code
 ICC = ITU Carrier Code as per ITU-T Rec. M.1400
 UAPC = Unique Access Point Code is carrier specific

- All TTI characters are from the T.50 character set
- SAPI and DAPI fields are defined as above
- Operator Specific bytes are user specified

SAPI[0] and DAPI[0] are set to All-0s

SAPI and DAPI Applications

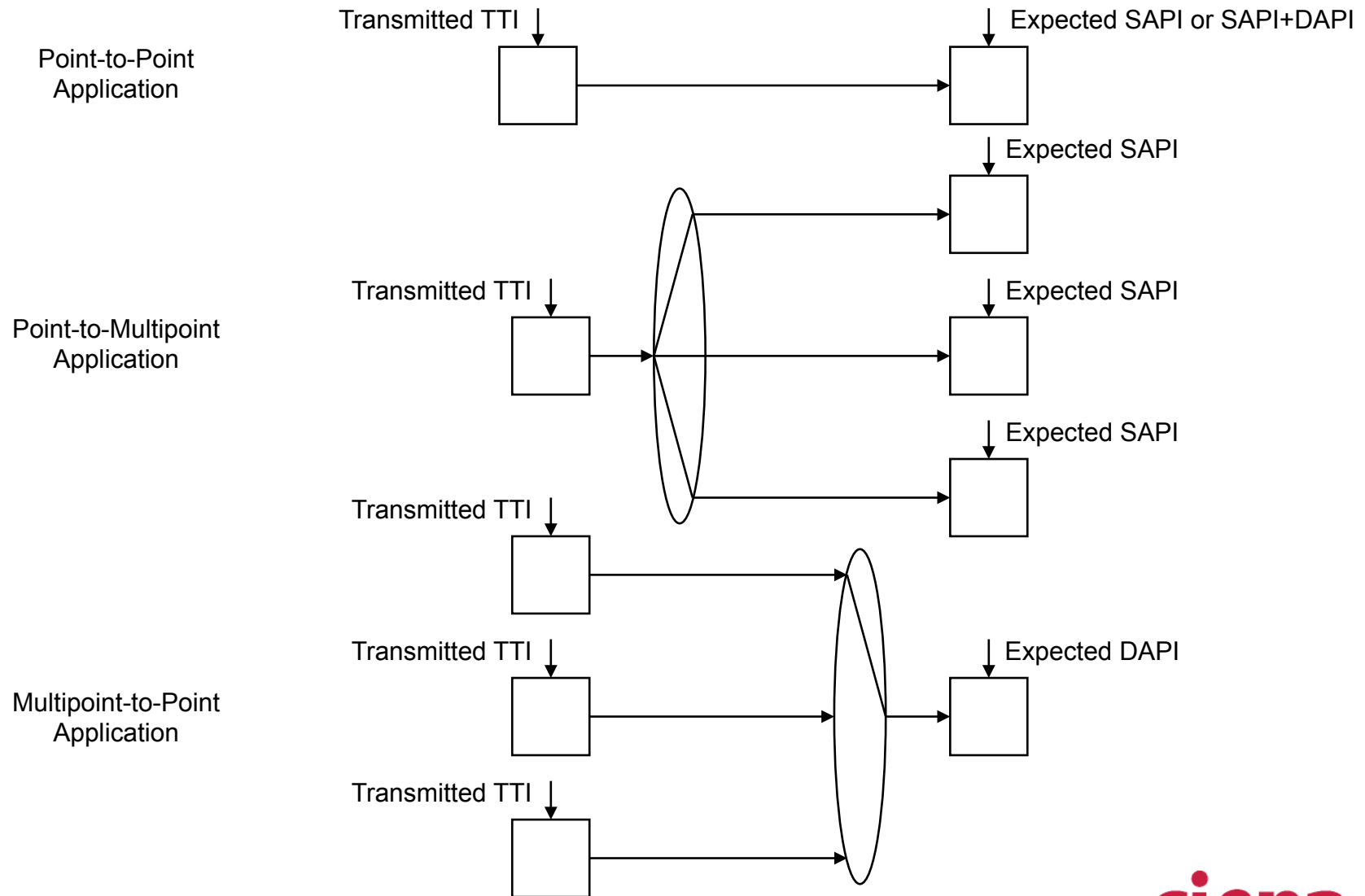

Overhead Descriptions – Maintenance Signals

FDI (Forward Defect Indication)

- Provided in the OOS to indicate optical AIS condition

PMI (Payload Missing Indication)

- Provided in the OTS/OMS layers to indicate loss of optical payload for downstream LOS-P suppression

STAT (Status – AIS, LCK)

- Provided in the ODU frame to allow detection of maintenance signal conditions
- Detection of All-1s results in Alarm Indication Signal (AIS) indication and detection of '0101' pattern results in Locked condition (LCK) indication

BDI (Backward Defect Indication)

- Provided in the OTS/OMS/OTU/ODU frame to allow detection of far-end defect conditions (single ended maintenance)

Mapping Overhead

PT (Payload Type, part of PSI multi-frame)

- Provided in the ODU (OPU OH) frames to allow detection of client payload mismatches
- Detection of mismatch between expected and received payload types results in Payload Label Mismatch (PLM) indication

JC (Justification Control), NJO/PJO

- Provided in the ODU frames (OPU OH) to control +1/0/-1 stuffing operations for client signal rate adaptation and +2/+1/0/-1 stuffing operations for ODUjk multiplexing
- NJO/PJO provide positive and negative stuffing opportunities for +/-45ppm client and ~+/-80ppm ODUjk multiplexing rate adaptation

Other Client Mapping/Multiplexing Specific Overhead

- VCAT OH – virtual concatenation overhead (NxODUk container creation)
- MSI – multiplex structure identifier overhead (ODUjk multiplexing)

Current OTN Standardization Efforts

OTU4/ODU4 (100G)

- Rate close to final definition (~112G)
- Proposed client signal list defined (ODUk, ODU2e, 100GbE, etc.)
- Support 10xODU2/ODU2e, 2xODU3+2/ODU2/ODU2e, 40xODU1, 80xODU0
- New multi-lane formats and modulation formats being discussed

Standardized support for ODU2e still being discussed

- Supports transparent 10GbELAN mapping
- Likely rate is ~11.096Gbps

ODU0 Standardization

- 2xODU0 multiplexed into ODU1, ODU0 multiplexing into other rates being discussed
- Geared toward efficient transport of GbE services

Standards and References

ITU-T Recommendations

- **G.709 - Interfaces for the Optical Transport Network (OTN)**
- **G.798 - Characteristics of optical transport network hierarchy equipment functional blocks**
- **G.808 - Generic protection switching - Linear trail and subnetwork protection**
- **G.870 - Terms and definitions for Optical Transport Networks (OTN)**
- **G.871 - Framework for optical transport network Recommendations**
- **G.872 - Architecture of optical transport networks**
- **G.873.1 - Optical Transport Network (OTN): Linear protection**
- **G.874 - Management aspects of the optical transport network element**
- **G.874.1 - Optical transport network (OTN): Protocol-neutral management information model for the network element view**
- **G.959.1 - Optical transport network physical layer interfaces**
- **G.8201 - Error performance parameters and objectives for multi-operator international paths within the Optical Transport Network (OTN)**
- **G.8251 - The control of jitter and wander within the optical transport network (OTN)**
- **G.Sup43 - Transport of IEEE 10G Base-R in Optical Transport Networks (OTN)**